

# FURUNO®

## 10.4" COLOR LCD DISPLAY SEARCHLIGHT SONAR Model CH-250

- High definition active matrix color LCD
- Choice of frequency: 60, 88 or 150 kHz
- BlackBox system configuration allows use of optional CRT or LCD monitors
- Target lock on a fish school or L/L position for a designated fishing area
- Pulse length automatically switched with range to optimize performance on all ranges
- A specific color can be shown in white to enhance the echo level display
- Instant selection of eight different operational modes
- Audible target detection freeing the operator from a continuous display watch
- Customized fishing menu



# Power search in eight modes for fishing and other sonar applications

The CH-250 is a revolutionary, high-performance searchlight sonar designed for a wide range of commercial fishing vessels. Fish and underwater objects are displayed on a compact color LCD screen. Target echoes are presented in 8 or 16 colors depending on the received echo strengths. The highest echo level is painted in red and next strongest echo in orange, and other colors follow with reducing echo levels. One of the echo strengths can be displayed in white to enhance the specific echo level. The background color may be customized for optimum viewing at day or night. An operating frequency can be selected from 60, 88 or 150 kHz.

The CH-250 is provided with eight operational modes including half or full circle scan, zoom, vertical scan, vertical sounder, the combination of full or half circle with vertical scan, full circle with history, full circle with strata and full circle with VideoPlotter. The combination of full circle and vertical scan mode helps evaluate the distribution of fish schools in horizontal and vertical planes simultaneously.

The CH-250 has another unique mode to view the vertical plane called "Cross Section Scan". When you find a specific echo, press the "CUSTOM MODE BUTTON" and then the cross section scan window appears.

The CH-250 provides three modes to track a targeted echo: manual mode, target lock mode and L/L mode. The target lock mode permits automatic tracking of a target fish school within a predetermined search zone after it has been acquired in manual operation. In the L/L mode, the beam is locked to the position (such as a fish shelter or reef) specified by the target marker. This mode can be enhanced with DGPS position input.

The compact display design allows a flexible and space-saving installation at your navigation station. With an optional interface unit, a conventional CRT or LCD monitor can be connected as a substitute, backup or remote display of the standard display unit. The low-profile hull unit requires only a limited space for installation. There is a choice of hull units, either 250 mm or 400 mm travel.

## CROSS SECTION SCAN

The CH-250 has a unique "Cross Section Scan" mode. You can instantly view the vertical plane in a specified direction by pressing the "CUSTOM MODE BUTTON". It is useful for evaluating the concentration and location of the targeted fish school or navigation purposes.

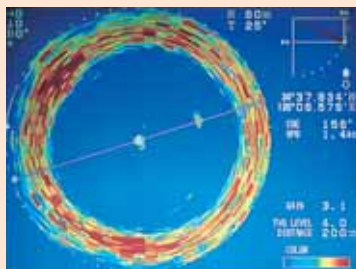

Press the "CUSTOM MODE BUTTON"

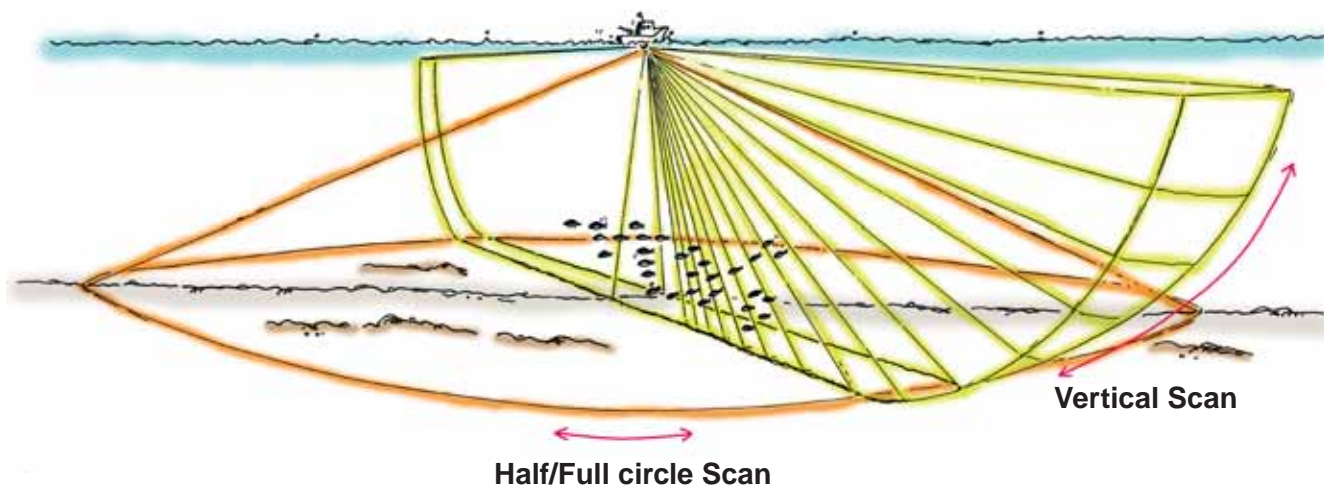
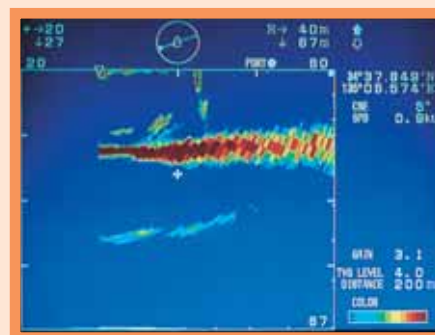
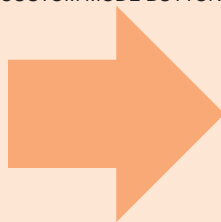

## FULL CIRCLE SCAN

The full circle scan helps to detect fish schools at any bearing, all around the vessel.

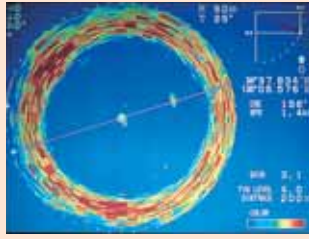

## VERTICAL SCAN

The vertical scan paints the bottom profile within a user-specified vertical plane. The cursor indicator reads slant range and soundome tilt.

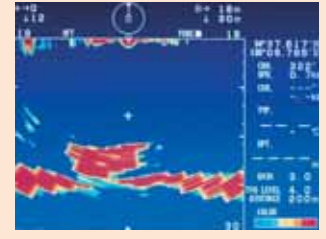

## Combination of FULL/HALF CIRCLE with VERTICAL SCAN

Combination of FULL CIRCLE with VERTICAL SCAN

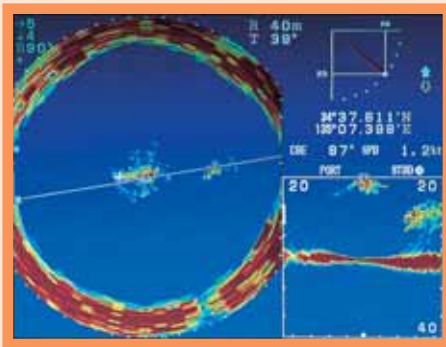

Combination of HALF CIRCLE with VERTICAL SCAN

A unique feature of this sonar is the mode integrating the two images shown to the left. This sonar image also can be switched to a Half Circle with Vertical scan.

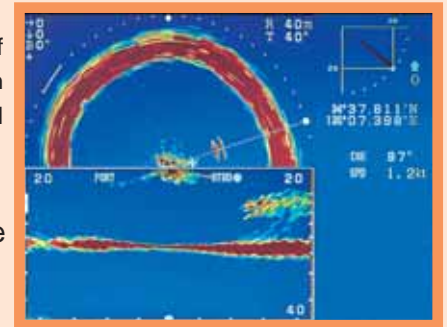

## VERTICAL SOUNDER

The vertical sounder displays how the depth and bottom hardness are changing ahead of own ship. When the soundome tilt is set to 90 degrees, the picture is the same as a vertical sounder. It displays fish schools and seabed conditions directly under the vessel.

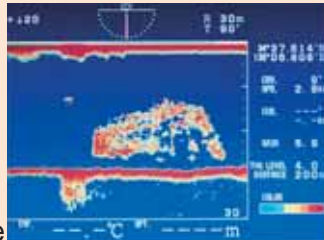

## FULL CIRCLE with VideoPlotter

Own ship track is monitored with respect to the sonar sounding area. Unrivaled feature for purse seining.



## Interconnection Diagram

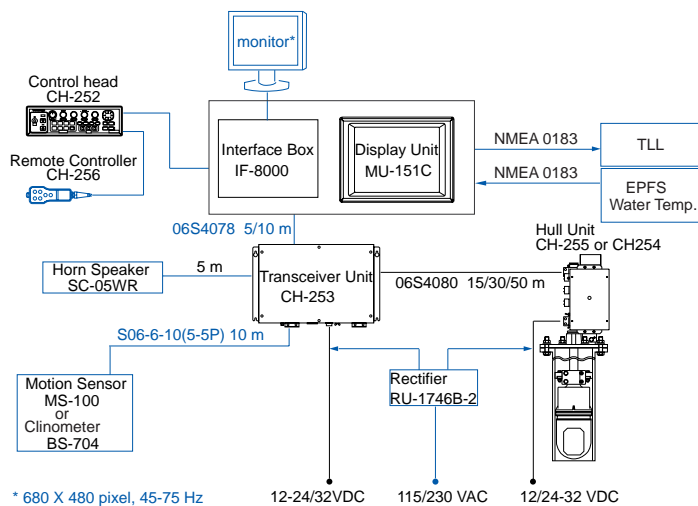

BlackBox configuration  
(with custom monitor)

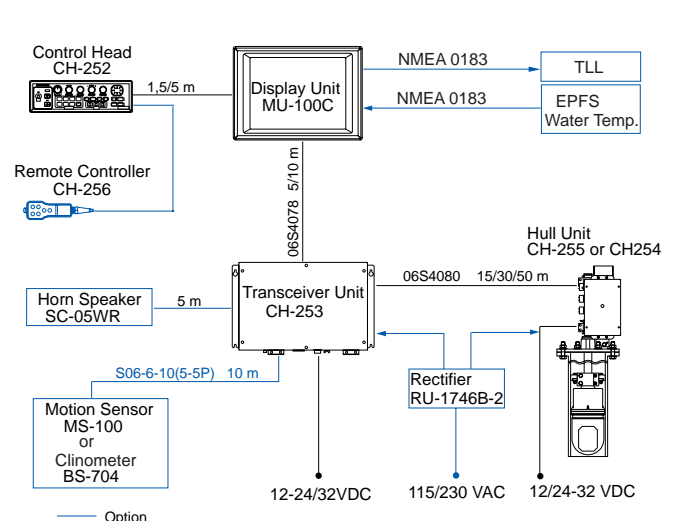

Standard configuration  
(with standard LCD monitor)

# SPECIFICATIONS OF CH-250

## 1. Range scales and Pulselength

150 kHz

Range	1	2	3	4	5	6	7	8	9	10	11	12	13	14	15
Meters	10	20	40	60	80	120	160	200	250	300	400	500	600	800	1000
Feet	40	80	120	200	300	400	500	600	700	800	1000	1500	2000	2500	3500
Fathoms	10	20	40	60	80	100	120	140	160	200	250	300	400	500	600
P/B	10	20	40	60	80	100	120	140	160	200	250	300	400	500	700
Time to train full circle (s)	7	7	7	7	7	10	12/13	14/16	16/20	18/24	22/32	26/40	30/48	38/64	46/81

Max scale depends on the system frequency. 1600 m (60 kHz), 1200 m (88 kHz), 1000 m (150 kHz).

Training speed is subject to the system frequency and range scales. Two speeds on long range scales.

- 2. **Display Unit** 10.4" TFT color LCD (VGA: 640 x 480 pixels)
- 3. **Color** 8 or 16 colors

- 4. **Display Mode**
  - (1) Full Circle scan (2) Zoom (x 1.5) (3) Vertical scan
  - (4) Vertical Sounder (5) Full/Half Circle and Vertical scan
  - (6) Full Circle and History (7) Full Circle and Strata
  - (8) Full Circle and VideoPlotter

- 5. **Audio Monitor** 1000 Hz
- 6. **TX Output Power** 0.8-1.2 kW

- 7. **Beamwidth (at -3 dB)**
  - 60 kHz: 15° (H) x 12° (V)
  - 88 kHz: 11.5° (H) x 9.5° (V)
  - 150 kHz: 6.5° (H) x 6.5° (V)

- 8. **Transducer Control**
  - Tilt** 0° to -180° at 3° or 6° steps (in vertical scan)  
+5° to -90° at 1° steps (in full circle scan)
  - Training Sector** Manual or automatic training at 6° or 12° steps in search sector 6°-360°

- Target Lock** By L/L or Echo position
- 9. **Interface** NMEA 0183 Ver 1.5, 2.0 (IEC 61162-1)
- Input:** DBS, DBT, DPT, GGA, GLL, HDG, HDM, MDA, MTW, RMA, RMC, VDR, VHW, VTG
- Output:** SSTLL

- 10. **Language** English, Spanish, Danish, Portuguese, French, Norwegian, Italian, Swedish, Thai

### Power Supply

Transceiver Unit 12-24/32 VDC, 55 W  
Hull Unit 12/24-32 VDC, 55 W  
(200 W while raising/lowering transducer)

**ENVIRONMENT** (Complies with IEC 60945)  
Display Unit: -15°C to +55°C  
Water proofing IEC IPX5, USCG CFR 46 (Display Unit)

### EQUIPMENT LIST

- Standard**
- 1. Display Unit MU-100C 1 unit
  - 2. Control Unit CH-252 1 unit
  - 3. Hull Unit CH-254 (travel 400 mm) or CH-255 (travel 250 mm) 1 unit
  - 4. Transceiver Unit CH-253
  - 5. Installation Materials and Spare Parts 1 set
  - 6. Interface Unit IF-8000 (BlackBox type only) 1 unit

- Option**
- 1. Remote Controller CH-256
  - 2. Rectifier RU-1746B-2
  - 3. External Speaker SC-05WR
  - 4. 1 m tall steel tank (06-007-1570), 1.8 m tall steel tank (SHJ-0001), 3.5 m tall steel tank (06-007-1571), 1 m tall FRP tank (SHJ-0022), 1.8 m tall FRP tank (06-007-1573), 1 m tall aluminum tank (OP10-5),
  - 5. NMEA Cable  
MJ-A6SPF0012-050 (5 m), MJ-A6SPF0011-050 (5 m), MJ-A6SPF0012-100 (10 m), MJ-A6SPF0011-100 (10 m),
  - 6. Motion Sensor MS-100 or Clinometer BS-704
  - 7. Interface Unit IF-8000

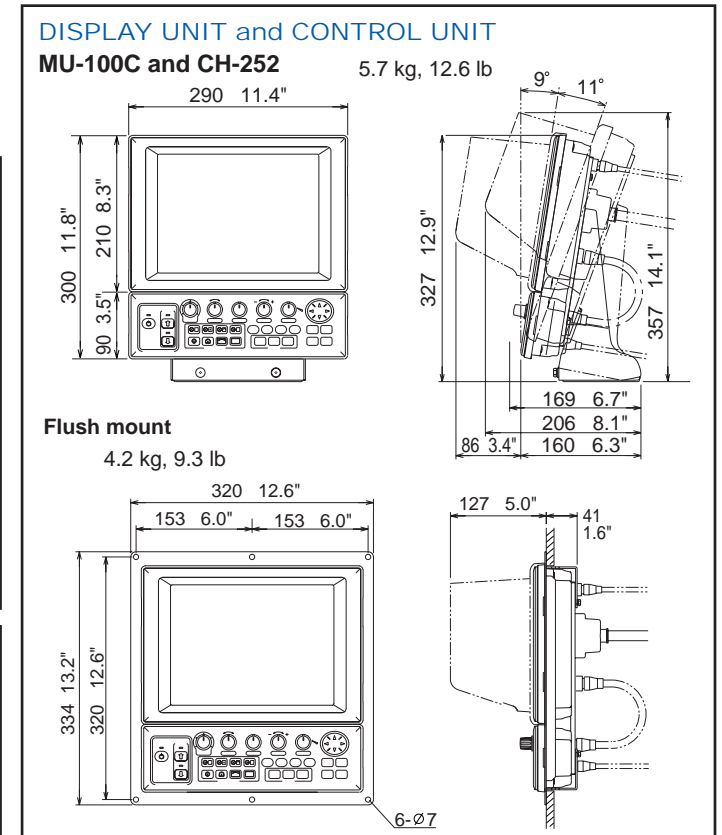
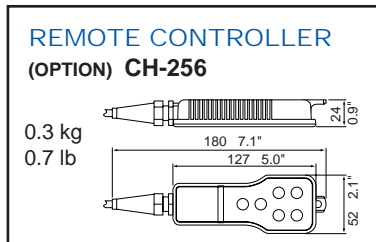
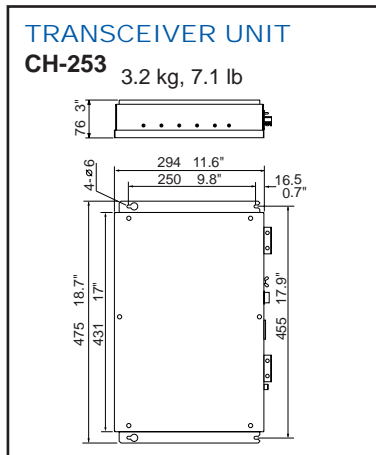
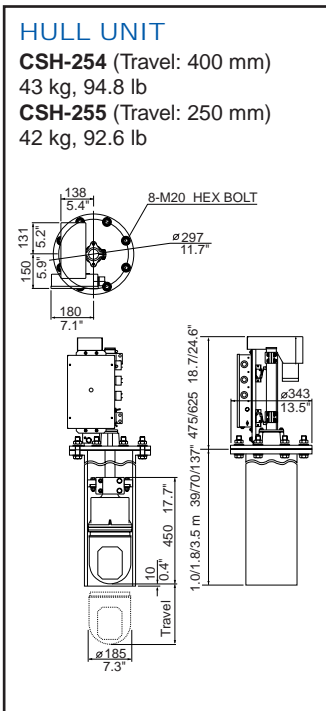

All brand and product names are registered trademarks, trademarks or service marks of their respective holders.

SPECIFICATIONS SUBJECT TO CHANGE WITHOUT NOTICE

#### FURUNO ELECTRIC CO., LTD.

Nishinomiya, Hyogo, Japan  
Phone: +81 (0)798 65-2111  
Fax: +81 (0)798 65-4200, 66-4622

#### FURUNO U.S.A., INC.

Camas, Washington, U.S.A.  
Phone: +1 360-834-9300  
Fax: +1 360-834-9400

#### FURUNO (UK) LIMITED

Havant, Hampshire, U.K.  
Phone: +44 23 9244 1000  
Fax: +44 23 9248 4316

#### FURUNO FRANCE S.A.S.

Bordeaux-Mérignac, France  
Phone: +33 5 56 13 48 00  
Fax: +33 5 56 13 48 01

#### FURUNO ESPAÑA S.A.

Madrid, Spain  
Phone: +34 91-725-90-88  
Fax: +34 91-725-98-97

#### FURUNO DANMARK AS

Hvidovre, Denmark  
Phone: +45 36 77 45 00  
Fax: +45 36 77 45 01

#### FURUNO NORGE A/S

Ålesund, Norway  
Phone: +47 70 102950  
Fax: +47 70 102951

#### FURUNO SVERIGE AB

Västra Frölunda, Sweden  
Phone: +46 31-7098940  
Fax: +46 31-497093

#### FURUNO FINLAND OY

Espoo, Finland  
Phone: +358 9 4355 670  
Fax: +358 9 4355 6710

#### FURUNO POLSKA Sp. z o.o.

Gdynia, Poland  
Phone: +48 58 669 02 20  
Fax: +48 58 669 02 21

#### FURUNO DEUTSCHLAND GmbH

Reilingen, Germany  
Phone: +49 4101 838 0  
Fax: +49 4101 838 111

#### FURUNO EURUS LLC

St. Petersburg, Russian Federation  
Phone: +7 812 767 15 92  
Fax: +7 812 766 55 52



09023N Printed in Japan

Catalogue No. E-381e

